

# MICROSCAN®

## NERLITE® BL 100x200 LED Backlight Series

**Description:** NERLITE Backlight Series (patent pending) provide sharp contrast to outline a part's shape, find edges and view openings such as drilled holes, allowing for various vision operations. In a low-profile industrial package providing optimal thermal management to the LEDs, models in the 100X200 series are a cost effective choice for applications where illuminated area size and uniformity are of importance. NERLITE Backlights are available in various wavelengths for strobe or continuous duty-cycles, all using industry standard M12 connectors.

**Applications:** Back lighting: to outline a parts shape, find edges, or detect openings (e.g. drilled holes).

### Part # Description

NER-AE00-3AF0G	NERLITE BL 100x200, R LED-D, CC
NER-AE00-3AG0G	NERLITE BL 100x200, W LED-D, CC
NER-AE00-3AC0G	NERLITE BL 100x200, B LED-D, CC
NER-AE00-3AH0G	NERLITE BL 100x200, G LED-D, CC
NER-AE00-3AJ0G	NERLITE BL 100x200, I LED-D, CC

#### Description Key Example

BL 00x00, R LED-D, 24V-C	
Family Designation: BL - Backlight	Color: R - Red, W - White, B - Blue, G - Green, I - Infrared
Backlight Size (mm - approx)	Delivery: D - Diffused
	Power: xxV-C - DC Volts Continuous, CC - Constant Current
	Source: LED - Light Emitting Diode



### Illumination & Electrical:

#### Light Characteristics:

Source	Color (nm)	Exp. Life	CC-Strobe <sup>1, 2, 3, 4</sup>			CC-Continuous <sup>1, 2, 4</sup>		
			Max. Current	Max. Vf	Min. Vf	Max. Current	Max. Vf <sup>5</sup>	Min. Vf <sup>5</sup>
LED	Red (625)	50k hrs.	1.00 A peak	17.16 V	11.32 V	700 mA	14.04 V	9.24 V
LED	Blue (470)	50k hrs.	950 mA peak	17.04 V	11.92 V	700 mA	15.96 V	11.16 V
LED	Green (530)	50k hrs.	950 mA peak	17.04 V	11.92 V	700 mA	15.96 V	11.16 V
LED	IR (850)	50k hrs.	1.00 A peak	20.72 V	12.96 V	700 mA	19.20 V	12.00 V
LED	White - 5500 Kelvin	50k hrs.	950 mA peak	17.04 V	11.92 V	700 mA	15.96 V	11.16 V

<sup>1</sup> CAUTION: Do not connect "CC" (Constant Current) lights directly to 24 volts; use a CC controller or driver.

<sup>2</sup> 24VDC +/- 3% is the recommended input to PP6xx controllers for CC-Strobe models;

24VDC +/- 10% is the recommended input to LCxx drivers.

<sup>3</sup> Maximum pulse width = 1ms, maximum frequency = 60Hz

<sup>4</sup> Exceeding max. current, pulse width or frequency voids product warranty.

<sup>5</sup> Vf = Forward Voltage in Volts DC; used in calculating heat dissipation in CC-Continuous applications that use a PP6XX controller.

#### CE Conformity:

Yes

#### Lighting Technique:

Diffuse Backlight

#### Active Area:

100mm x 200 mm  
(3.94 in. x 7.87 in.)

#### Environmental:

##### Max. Operating Humidity:

85% non-condensing

##### Operating Temp.:

40°C (104°F)

##### Storage Temp.:

50°C (122°F)

#### Mechanical:

##### L x W x H (mm/in.):

120.0 mm x 260.0 mm x 23.5 mm

(4.72 in. x 10.24 in. x 0.93 in.)

(4) 4.3 mm [0.17 in.] thru holes

Black Anodized Aluminum

1.1 kgs. (2.4 lbs.)

##### Mounting:

##### Housing Material:

##### Weight:

#### Connectors:

##### Connector Type:

M12 "A" Code Male, 4 Pos:

Pin # 1 = +  
Pin # 2 = nc  
Pin # 3 = -  
Pin # 4 = nc  
Connector Shell = Shield

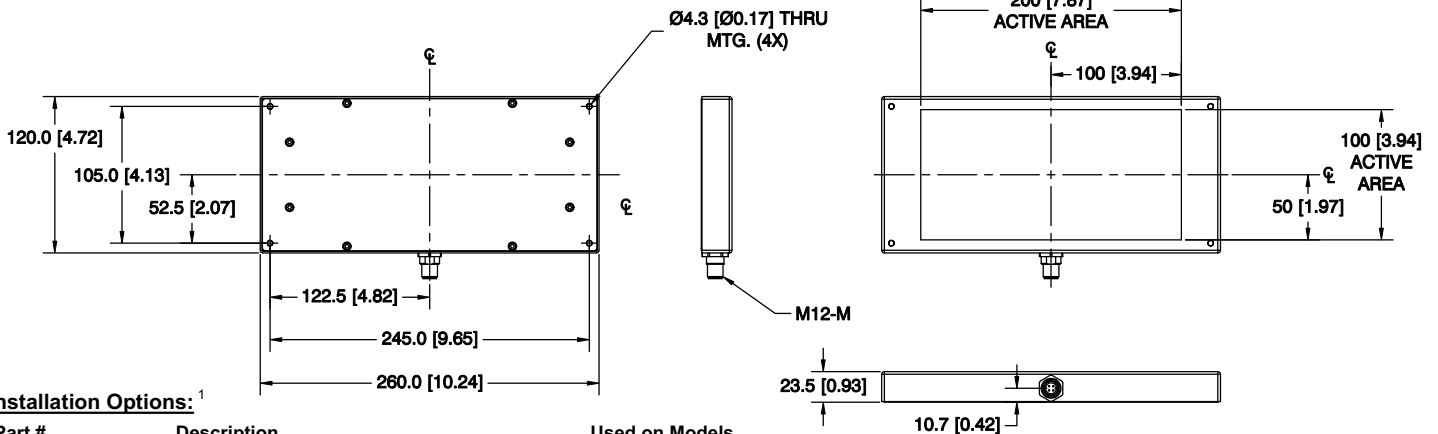

### Installation Options:<sup>1</sup>

Part #	Description	Used on Models
NER-BA10-0AS0	PP600, 2 Chnl. CC Cntrl, 24VDC, Push Button <sup>2, 3</sup>	CC-Strobe
NER-BA10-0AT0	PP610, 2 Chnl. CC Cntrl, 24VDC, PB/RS232 <sup>2, 3</sup>	CC-Strobe
NER-BA10-0AB0	LC50, 700 mA CC Driver, w/Terminal Block <sup>2</sup>	CC-Continuous
NER-BA10-0AK0	LC100, 700 mA CC Driver, w/Terminal Block <sup>2</sup>	CC-Continuous
NER-BA00-0AA0	DSP60, 24VDC, 2.5A DIN Mount Power Supply	PP6xx, LC50, & LC100
NER-BA00-0AB0	DSP100, 24VDC, 4.2A DIN Mount Power Supply	PP6xx, LC50, & LC100
NER-DA00-0AB0	AC Power Cord, US, 1.8 M (6.0 ft.)	DIN Mount PS
NER-DA00-0AC0	AC Power Cord, EU, 2.5 M (8.2 ft.)	DIN Mount PS
NER-DA00-0AD0	AC Power Cord, UK, 2.0 M (6.6 ft.)	DIN Mount PS
NER-DA00-0AA0	Power Cable, Flying Leads - M12F, 3.0 M (9.8 ft.)	(all)

<sup>1</sup> Constant Current (CC) controller or driver is required.

<sup>2</sup> CC controllers and drivers require a DC power supply; choose one from above.

<sup>3</sup> Refer to PP600 Heat Dissipation application note if considering CC-Continuous mode applications (not recommended).



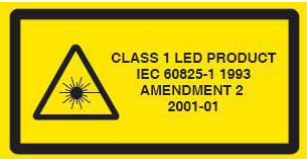

When provided, affix peel and stick eye safety warning labels to a system location visible to system operators and supporting personnel.

**WARNINGS:** For safe use of this product, observe the following warnings:

- Handling:** Surfaces hot during and after operation, avoid contact.
- Service:** No user serviceable parts inside, contact supplier for service.
- Eye Safety:** Products containing LEDs fall under the IEC standard for laser product safety (IEC 60825-1). Please refer to the IEC classifications and categorization of NERLITE products below for safe operation.
- IEC Laser Safety Class Definitions pertinent to NERLITE LED products:**

IEC Class Code	Definition
1	Considered as safe to eye and skin under all reasonably foreseeable conditions of operation.
1M	Considered as safe to eye and skin under all reasonably foreseeable conditions of operation, provided they are not viewed with magnifying optics of any kind.
2	Will not cause permanent eye damage under all reasonably foreseeable conditions of operation, provided that any exposure may be terminated by the blink reflex of the eye. Since this assumes the eye can detect this radiation, the wavelength range is limited to visible light (400nm to 700nm).
- IEC Laser Safety Class Codes of NERLITE LED Machine Vision Illuminators**

IEC Class Code	NERLITE Products (Refer to Model Descriptions)
1	R LED, W LED, G LED, I LED
1M	U LED
2	B LED, B1 LED, B3 LED, R1 LED, R3 LED, W1 LED, W3 LED, G1 LED, G3 LED, I1 LED, DUAL AXIS LIGHTS containing I LED
- Training:** Customers are encouraged to document their unique application and instruct employees on procedures to limit exposure to LED radiation. The documentation and instruction should include but not necessarily be limited to:
  - Operational overview of equipment including LED lighting.
  - Need for personal protection (e.g. protective eyewear, UV protective eyewear)
  - Understanding hazard controls (e.g. warning signs)
  - Bio-effects of LED radiation upon the eyes and skin (refer to <http://www.icnirp.de/documents/led.pdf> for the International Commission on Non-ionizing Radiation Protection's statement on "LEDS and Laser Diodes: Implications for Hazard Assessment")
- General LED Precautions:**

These devices contain visible and non-visible LEDs – Light Emitting Diodes.
- WARNING – RISK OF DISCOMFORT:**

Observation of the Class 1 and 2 code definitions are substantial for eye protection.

- Flashing LED Precautions:**

This device contains LEDs – Light Emitting Diodes – that are flashing (aka strobing or pulsing) during operation.
- WARNING – RISK OF DISCOMFORT:**

Flashing (aka strobing or pulsing) lights have been known to cause discomfort in people; you can prevent this by taking precautions during use.

- Ultra Violet (UV) LED Precautions:**

This device contains UV Light LEDs – Ultra Violet Light Emitting Diodes. The LED during operation radiates intense UV light.
- WARNING – RISK OF CORNEA AND LENS DAMAGE:**

Viewing the LED output with certain optical instruments (for example: eye loupes, magnifiers and microscopes) within a distance of 100 mm may pose an eye hazard. During operation, these LEDs radiate UV light, requiring that precautions must be taken to prevent looking directly at the UV light with unprotected eyes. Do not look directly, or through an optical system, into the UV light. When there is a possibility to receive a reflection of light, protect your eyes by using UV light protective glasses so that light will not reach eyes directly.

- Blue LED Precautions:**

This device contains Blue LEDs – Blue Light Emitting Diodes.
- WARNING – RISK OF RETINAL DAMAGE:**

During operation, these LEDs radiate Blue light, requiring that precautions must be taken to prevent looking directly at the Blue light with unprotected eyes. Eye protection from visible "blue light" LED radiation can be provided by normal aversion responses (e.g. looking away from light source, blink reflex).

- Infra Red (IR) LED Precautions:**

This device contains IR LEDs – IR Light Emitting Diodes.
- WARNING – THERMAL HAZARD: RISK OF LENS DAMAGE:**

During operation, these LEDs radiate non-visible thermal energy. Eye hazards are dependent upon brightness of the source and since IR LED output is non-visible, precautions must be taken to prevent looking toward the output of the LED assembly.