

MICROSCAN®

NERLITE® ICM-1 Intensity Control Module

PRODUCT DESCRIPTION: The ICM-1, M/D, (Intensity Control Module - 1 Channel, Manual/Digital) provides a single channel alternative to our VPS (Variable Power Supply) for all continuous NER LED lights requiring < 3 amps of current (2A for 24 Volt model). The ICM-1 delivers precise lighting intensity control through either manual or digital adjustment modes (switch selectable at the unit). In manual mode, light intensity is adjusted by a potentiometer that is accessible through a port in the side of the unit. In digital mode, intensity is controlled from a vision system through digital signaling (standard 5V TTL), offering precise adjustment through a 100 step range. The ICM's digital mode provides the foundation for a system-level feedback loop, wherein the vision system can adjust light intensity without user intervention, automatically compensating for changing illumination needs (e.g. multiple parts on a line, each with varying surface features). A DC power supply is required (see Accessories list). A control cable #030-008400 is included.

Model #	Description
NER-010502700	ICM-1, M/D, 12V-C
NER-010502701	ICM-1, M/D, 24V-C

Electrical:

Power Characteristics:

Model	Voltage/Current (max.)	
	12V-C	24V-C
Input Current	3.0 A ¹	2.0 A ¹
Output Current	3.0 A ¹	2.0 A ¹
Output Voltage	4 - 11 VDC	11 - 23 VDC

¹ Based on output demand

Control Signals: 5V TTL (see control functions notes, pg. 2)
CE Conformity: Yes

Mechanical:
L x W x H: 79.4 mm x 66.7 mm x 28.6 mm
 (3.13 in. x 2.63 in. x 1.13 in.)

Weight: 0.14 kg (0.3 lbs.)

Environmental:
Max. Operating Humidity: 5-95% non-condensing
Operating Temp.: 0°C to 40°C (32°F to 104°F)
Storage Temp.: -30°C to 85°C (-86°F to 185°F)

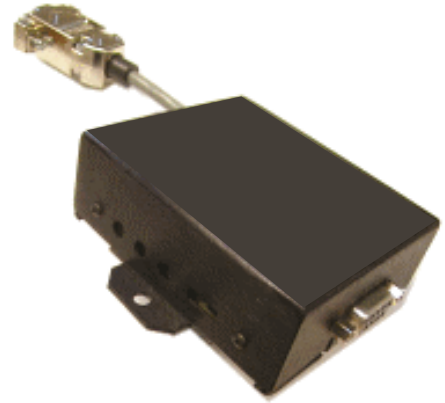

Accessories:

Part #	Description	Models Used On
NER-010502601	CPS-24T, 24VDC US w/9-pin D-sub	24V-C
NER-010502602	CPS-24T, 24VDC EU w/9-pin D-sub	24V-C
NER-010500301	CPS-12 3.5A, 12VDC, US Cord	12V-C
NER-010500303	CPS-12 3.5A, 12VDC, EU Cord	12V-C
NER-030003702	Ext. Cable, Continuous, 1.8 M (6 ft.)	12V-C
NER-030003703	Ext. Cable, Continuous, 3.0 M (10 ft.)	12V-C
NER-030003601	Y cable, 2 Lights, 9 pin D-sub Cont.	12V-C

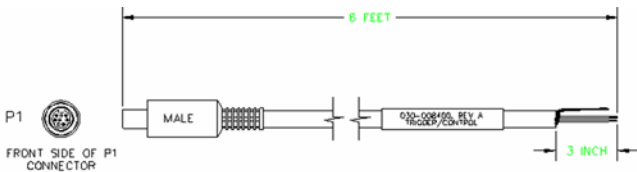

030-008400 Control Cable

See "Cables/Connectors" chart below for pin-to-signal reference

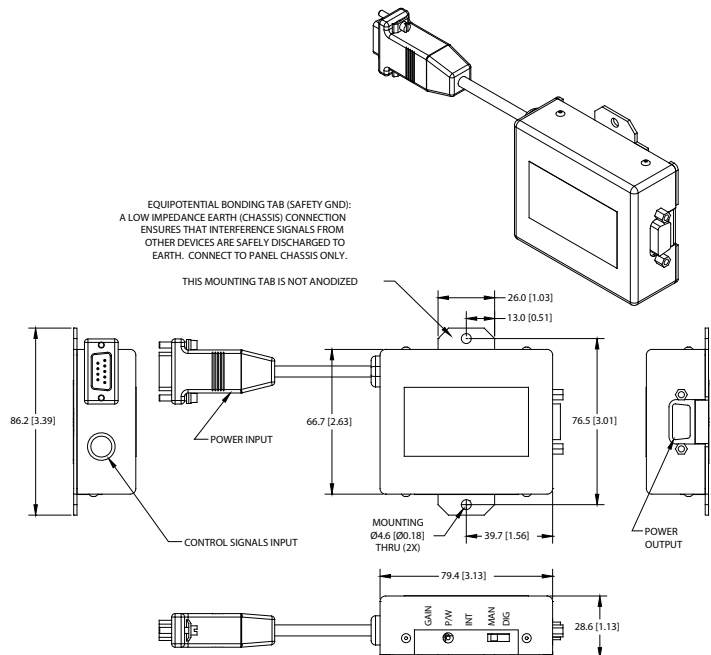

NERLITE® ICM-1 Intensity Control Module Control Function Notes/QuickSetup

Control Function Notes

- **Signal levels:** 5V TTL
- **Adjustment:** Via digital potentiometer; variable output in 100 increments via two TTL signals - INCREMENT and UP/DN.
- **Variable intensity control is accomplished by applying:**
 1. **UP/DN Control:**
 - A 5V signal (logic level high) will cause the intensity (voltage output) to increase.
 - A 0V signal (logic level low) will cause the intensity (voltage output) to decrease.
 2. **INCREMENT Control:** A clock style signal will increment the intensity by a factor of 1/100 the range toward the direction as signaled by UP/DN on every high to low transition.
 - Sequence:** UP/DN must lead INCREMENT by 100ns
 - Maximum frequency:** 100kHz with max TRISE/TFALL of 4 µs per
 - Number of increments:** 100

Quick Setup – Manual Mode

1. Connect input power (+12 or +24 VDC, depending on model) and ground to the appropriate pins of the INPUT CONNECTOR (see "Cables/Connectors" chart below).
2. Set mode switch to MANUAL.
3. Connect lighthouse to the appropriate pins of the OUTPUT CONNECTOR (see "Cables/Connectors" chart below).
4. Adjust light intensity with the INTENSITY ADJUSTMENT potentiometer (clockwise to increase)

Quick Setup – Digital Mode

1. Connect input power (+12 or +24 VDC, depending on model) and ground to the appropriate pins of the INPUT CONNECTOR (see "Cables/Connectors" chart below).
2. Set mode switch to DIGITAL.
3. Connect the UP/DN, INCREMENT and GROUND control signals on the CONTROL CONNECTOR to your vision system's I/O outputs (TTL level). Observe control functions as stated above in "Control Function Notes".
4. Connect lighthouse to the appropriate pins of the OUTPUT CONNECTOR (see "Cables/Connectors" chart below).
5. Initialize your vision system.

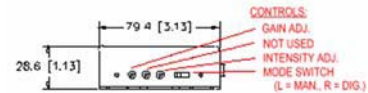

Control Locations

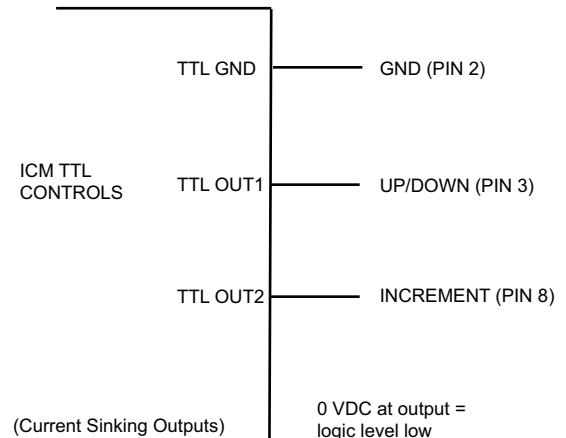

Typical Interface for Digital Mode

Cables/Connectors:

	Connector	Pin #	1	2	3	4	5	6	7	8	9
Input (12V)	9 pin D-sub Male		n/c	GND	GND	+12VDC	+12VDC	n/c	n/c	n/c	n/c
Input (24V)	9 pin D-sub Male		n/c	n/c	n/c	n/c	n/c	+24VDC	+24VDC	GND	GND
Output (12V)	9 pin D-sub Female		+12VDC (Fan)	GND (Fan)	GND (Light)	+12VDC (Light)	+12VDC (Light)	n/c	n/c	n/c	n/c
Output (24V)	9 pin D-sub Female		+24VDC (Fan)	GND (Fan)	n/c	n/c	n/c	+24VDC (Light)	+24VDC (Light)	GND (Light)	GND (Light)
Control (12 & 24 V)	8 pin Mini-DIN, Female		n/a	GND	UP/DN	n/c	n/c	n/c	n/c	INCREMENT	