

MICROSCAN®

NERLITE® BL 71x88 LED Backlight Series

Description: NERLITE Backlight Series (patent pending) provide sharp contrast to outline a part's shape, find edges and view openings such as drilled holes, allowing for various vision operations. High intensity and uniformity are packed into a low-profile industrial package providing optimal thermal management to the LEDs. Edge to Edge lighting provides the unique ability to mate multiple lights to provide larger illuminated areas. NERLITE Backlights are available in various wavelengths for strobe or continuous duty-cycles, all using industry standard M12 connectors.

Applications: Back lighting: to outline a parts shape, find edges, or detect openings (e.g. drilled holes).

Part #	Description
NER-AB08-4AA0G	NERLITE BL 71X88, R LED-D, 24V-C
NER-AB00-4AA0G	NERLITE BL 71X88, R LED-D, CC
NER-AB08-4AB0G	NERLITE BL 71X88, W LED-D, 24V-C
NER-AB00-4AB0G	NERLITE BL 71X88, W LED-D, CC
NER-AB08-4AC0G	NERLITE BL 71X88, B LED-D, 24V-C
NER-AB00-4AC0G	NERLITE BL 71X88, B LED-D, CC
NER-AB08-4AD0G	NERLITE BL 71X88, G LED-D, 24V-C
NER-AB00-4AD0G	NERLITE BL 71X88, G LED-D, CC
NER-AB08-4AE0G	NERLITE BL 71X88, I LED-D, 24V-C
NER-AB00-4AE0G	NERLITE BL 71X88, I LED-D, CC

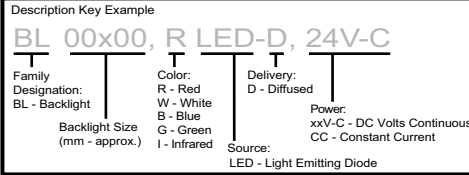

Illumination & Electrical:

Lighting Technique: Diffuse Backlight
Active Area: 88 mm x 71 mm
 (3.48 in. x 2.78 in.)

Light Characteristics:

Source	Color (nm)	Exp. Life	CC (Strobe Mode) ^{1,2,3,4}			24V-C ⁶
			Max. Current	Max. Vf ⁵	Min. Vf ⁵	Max. Current
LED	Red (640)	50k hrs.	5.01 A peak	19.9 V	13.4 V	170 mA
LED	Blue (470)	50k hrs.	9.00 A peak	16.4 V	12.9 V	310 mA
LED	Green (528)	50k hrs.	7.98 A peak	16.6 V	12.1 V	300 mA
LED	IR (880)	50k hrs.	7.50 A peak	15.8 V	9.9 V	220 mA
LED	White - 6500 Kelvin	50k hrs.	9.00 A peak	14.7 V	12.0 V	330 mA

¹ CAUTION: Do not connect "CC" (Constant Current) lights directly to 24 volts; a CC Controller is required.
² 24VDC +/- 3% is the recommended input to the PP6xx controllers.
³ Maximum pulse width = 1ms, maximum frequency = 60Hz
⁴ Exceeding max. current, pulse width or frequency voids product warranty.
⁵ Vf = Forward Voltage in Volts DC; used in calculating heat dissipation in multi light CC-Strobe applications.
⁶ 24VDC +/- 1% is the recommended input to 24V-C configurations.

CE Conformity: Yes

Mechanical:

L x W x H (mm/in.): 81.6 mm x 88.3 mm x 15.2 mm
 (3.21 in. x 3.48 in. x 0.60 in.)
Mounting: (2) M3 Counter Bores
Housing Material: Black Anodized Aluminum
Weight: 0.14 kgs. (0.30 lbs.)

Environmental:

Max. Operating Humidity: 85% non-condensing
Operating Temp.: 40°C (104°F)
Storage Temp.: 50°C (122°F)

Cables/Connectors:

Cable Length: 150mm (6.0 in.)
Connector Type: M12 "A" Code Male, 4 Pos:
 Pin # 1 = + 2 1
 Pin # 2 = nc 3 1
 Pin # 3 = - 3 4
 Pin # 4 = nc 3 4
 Connector Nut = Shield

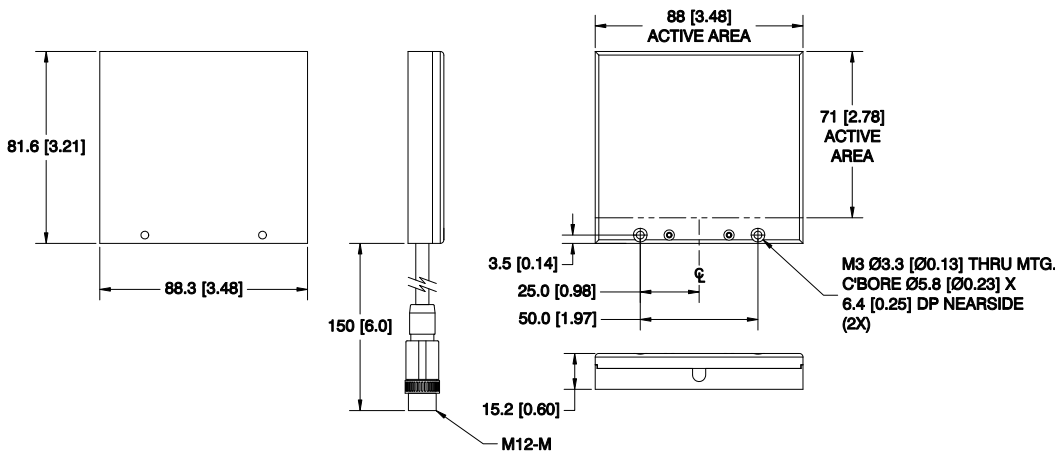

Installation Options:¹

Part #	Description	Used on Models
NER-BA10-0AS0	PP600, 2 Chnl. CC Cntrl, 24VDC, Push Button ^{2,3}	CC-Strobe
NER-BA10-0AT0	PP610, 2 Chnl. CC Cntrl, 24VDC, PB/RS232 ^{2,3}	CC-Strobe
NER-BA00-0AA0	DSP60, 24V, 2.5A, DIN Mount Power Supply	24V-C & PP6xx
NER-BA00-0AB0	DSP100, 24V, 4.2A DIN Mount Power Supply	24V-C & PP6xx
NER-DA00-0AB0	AC Power Cord, US, 1.8 M (6.0 ft.)	DIN Mount PS
NER-DA00-0AC0	AC Power Cord, EU, 2.5 M (8.2 ft.)	DIN Mount PS
NER-DA00-0AD0	AC Power Cord, UK, 2.0 M (6.6 ft.)	DIN Mount PS
NER-DA00-0AA0	Power Cable, Flying Leads - M12F, 3.0 M (9.8 ft.)	(all)

¹ Constant Current (CC) controller required for CC powered lights, not required for 24V-C lights.
² CC controllers require a DC power supply; choose one from above.
³ Refer to PP600 Heat Dissipation application note when configuring multi light CC-Strobe applications.





When provided, affix peel and stick eye safety warning labels to a system location visible to system operators and supporting personnel.

WARNINGS: For safe use of this product, observe the following warnings:



Handling: Surfaces hot during and after operation, avoid contact.



Service: No user serviceable parts inside, contact supplier for service.



Eye Safety: Products containing LEDs fall under the IEC standard for laser product safety (IEC 60825-1). Please refer to the IEC classifications and categorization of NERLITE products below for safe operation.



IEC Laser Safety Class Definitions pertinent to NERLITE LED products:

IEC Class Code	Definition
1	Considered as safe to eye and skin under all reasonably foreseeable conditions of operation.
1M	Considered as safe to eye and skin under all reasonably foreseeable conditions of operation, provided they are not viewed with magnifying optics of any kind.
2	Will not cause permanent eye damage under all reasonably foreseeable conditions of operation, provided that any exposure may be terminated by the blink reflex of the eye. Since this assumes the eye can detect this radiation, the wavelength range is limited to visible light (400nm to 700nm).



IEC Laser Safety Class Codes of NERLITE LED Machine Vision Illuminators

IEC Class Code	NERLITE Products (Refer to Model Descriptions)
1	R LED, W LED, G LED, I LED
1M	U LED
2	B LED, B1 LED, B3 LED, R1 LED, R3 LED, W1 LED, W3 LED, G1 LED, G3 LED, I1 LED, DUAL AXIS LIGHTS containing I LED



Training: Customers are encouraged to document their unique application and instruct employees on procedures to limit exposure to LED radiation. The documentation and instruction should include but not necessarily be limited to:

- Operational overview of equipment including LED lighting.
- Need for personal protection (e.g. protective eyewear, UV protective eyewear)
- Understanding hazard controls (e.g. warning signs)
- Bio-effects of LED radiation upon the eyes and skin (refer to <http://www.icnirp.de/documents/led.pdf> for the International Commission on Non-ionizing Radiation Protection's statement on "LEDS and Laser Diodes: Implications for Hazard Assessment")



General LED Precautions:

These devices contain visible and non-visible LEDs – Light Emitting Diodes.



WARNING – RISK OF DISCOMFORT:

Observation of the Class 1 and 2 code definitions are substantial for eye protection.



Flashing LED Precautions:

This device contains LEDs – Light Emitting Diodes – that are flashing (aka strobing or pulsing) during operation.



WARNING – RISK OF DISCOMFORT:

Flashing (aka strobing or pulsing) lights have been known to cause discomfort in people; you can prevent this by taking precautions during use.



Ultra Violet (UV) LED Precautions:

This device contains UV Light LEDs – Ultra Violet Light Emitting Diodes. The LED during operation radiates intense UV light.



WARNING – RISK OF CORNEA AND LENS DAMAGE:

Viewing the LED output with certain optical instruments (for example: eye loupes, magnifiers and microscopes) within a distance of 100 mm may pose an eye hazard.

During operation, these LEDs radiate UV light, requiring that precautions must be taken to prevent looking directly at the UV light with unprotected eyes. Do not look directly, or through an optical system, into the UV light. When there is a possibility to receive a reflection of light, protect your eyes by using UV light protective glasses so that light will not reach eyes directly.



Blue LED Precautions:

This device contains Blue LEDs – Blue Light Emitting Diodes.



WARNING – RISK OF RETINAL DAMAGE:

During operation, these LEDs radiate Blue light, requiring that precautions must be taken to prevent looking directly at the Blue light with unprotected eyes. Eye protection from visible "blue light" LED radiation can be provided by normal aversion responses (e.g. looking away from light source, blink reflex).



Infra Red (IR) LED Precautions:

This device contains IR LEDs – IR Light Emitting Diodes.



WARNING – THERMAL HAZARD: RISK OF LENS DAMAGE:

During operation, these LEDs radiate non-visible thermal energy. Eye hazards are dependent upon brightness of the source and since IR LED output is non-visible, precautions must be taken to prevent looking toward the output of the LED assembly.